

Laser-to-cavity locking employing an electro-optic modulator for mHz-linewidth lasers and gravitational wave detection

1. Consider the following schematic of a Pockels cell that is widely used as electro-optic modulator (EOM), meaning that an electronic signal affects the optical field via the (linear) electro-optic effect, known also as the Pockels effect.

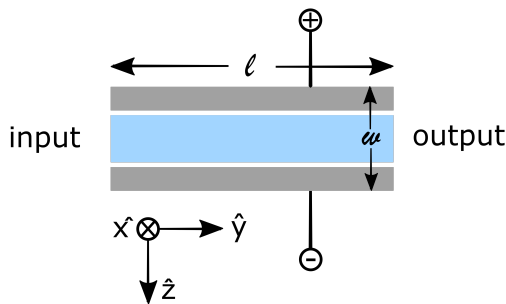

(a) Schematic of a Pockels cell with electrodes (grey) of distance w . The length of the crystal is l and the crystal orientation corresponds to the sketched coordinate system.

(b) Commercial Pockels cell (Thorlabs)

Parallel to the top and bottom surfaces of the crystal, there are metal strips that act as electrodes separated by $w = 5\mu\text{m}$ and of length $l = 5\text{mm}$. The applied voltage results in an index modulation via the electro-optic effect in the crystal and therefore in a phase shift.

Assume that the waveguide is fabricated of LiIO_3 and the principle axis of the material is oriented as shown in the figure. The field propagating is polarized along the x-axis and the wavelength is $1.5\mu\text{m}$.

On the following page, you find the electro-optic coefficients for different crystals and materials. These coefficients allow you to write the permittivity tensor κ , defined via $\vec{E} = \kappa\vec{D}$, as a function of the applied field according to

$$\kappa_{ij}(E) = \kappa_{ij}^0 + \frac{1}{\epsilon_0} r_{ijk} E_k$$

- (a) Derive a relationship between these electro-optic coefficients r_{ijk} and the second order susceptibility tensor $\chi_{nkl}^{(2)}$. You can start knowing that:

$$\vec{D} = \epsilon_0 \epsilon \vec{E}(\omega) + \epsilon_0 \chi^{(2)} \vec{E}(0) \vec{E}(\omega) + \text{higherorder terms}$$

- (b) The impermeittivity tensor is related to the refractive index n by $\kappa = \frac{1}{\epsilon_0 n^2}$. For simplicity we replace (ij) by a simple index (i) having: $(11) = (xx) = 1$, $(22) = (yy) = 2$, $(33) = (zz) = 3$, $(23) = (yz) = (32) = (zy) = 4$, $(13) = (xz) = (31) = (zx) = 5$ and $(12) = (xy) = (21) = (yx) = 6$. Now we have for the impermeittivity tensor:

$$\kappa_i(E) = \kappa_i^0 + \frac{1}{\epsilon_0} r_{ij} E_j \quad j = 1, 2, 3; i = 1, 2, \dots, 6$$

with κ_i^0 the original impermeittivity tensor without the presence of the external electric field and $\Delta\kappa = \Delta\left(\frac{1}{\epsilon_0 n^2}\right) = \frac{1}{\epsilon_0} r_{ij} E_j$ the change in the impermeittivity.

Derive an expression for the phase shift as a function of the applied voltage that is experienced by an optical wave travelling through the Pockels cell.

- (c) Use the electro-optic coefficients for LiIO_3 and LiNbO_3 to determine the voltage V_π for both materials. V_π is the voltage for which a phase shift of π is achieved.

Table 9-2 (continued)

Substance	Symmetry	Wavelength λ (μm)	Electrooptic Coefficients r_{ik} (10^{-12} m/V)	Index of Refraction n_i	n^2r (10^{-12} m/V)	Dielectric Constant* $\epsilon_i(\epsilon_0)$
Bi ₁₂ SiO ₂₀	23	0.633	$r_{41} = 5.0$	$n_o = 2.54$	82	
CdSe	6 mm	3.39	(S) $r_{13} = 1.8$	$n_o = 2.452$		(T) $\epsilon_1 = 9.70$
			(T) $r_{33} = 4.3$	$n_e = 2.471$		(T) $\epsilon_3 = 10.65$
α -ZnS (wurtzite)	6 mm	0.633	(S) $r_{13} = 0.9$	$n_o = 2.347$		(S) $\epsilon_1 = 9.33$
Pb _{0.814} La _{0.214} (Ti _{0.6} Zr _{0.4})O ₃ (PLZT)	∞m	0.546	$n^2r_{33} - n^2r_{13} = 2320$	$n_o = 2.360$		(S) $\epsilon_1 = 10.20$
				$n_e = 2.55$		(T) $\epsilon_1 = \epsilon_2 = 8.7$
LiIO ₃	6	0.633	(S) $r_{13} = 4.1$	$n_o = 1.8830$		
			(S) $r_{41} = 1.4$	(S) $r_{33} = 6.4$		
Ag ₃ AsS ₃	3m	0.633	(S) $n^2r_e = 70$	(S) $r_{31} = 3.3$	$n_o = 1.7367$	
			(S) $n^2r_{22} = 29$		$n_e = 3.019$	
LiNbO ₃ ($T_c = 1230^\circ\text{C}$)	3m	0.633	(T) $r_{13} = 9.6$	(S) $r_{13} = 8.6$	$n_o = 2.286$	(T) $\epsilon_1 = \epsilon_2 = 78$
			(T) $r_{22} = 6.8$	(S) $r_{22} = 3.4$	$n_e = 2.200$	(T) $\epsilon_3 = 32$
			(T) $r_{33} = 30.9$	(S) $r_{33} = 30.8$		(S) $\epsilon_1 = \epsilon_2 = 43$
			(T) $r_{31} = 32.6$	(S) $r_{31} = 28$		(S) $\epsilon_3 = 28$
			(T) $r_e = 21.1$			
		1.15	(T) $r_{22} = 5.4$		$n_o = 2.229$	
			(T) $r_e = 19$		$n_e = 2.150$	
		3.39	(T) $r_{22} = 3.1$	(S) $r_{33} = 28$	$n_o = 2.136$	
			(T) $r_e = 18$	(S) $r_{22} = 3.1$	$n_e = 2.073$	
				(S) $r_{13} = 6.5$		
				(S) $r_{31} = 23$		

Figure 2: electro-optic coefficients. (T) for the range of radio frequencies and (S) for optical frequencies.

- One intriguing application of the Pockels cell is in the Pound-Drever-Hall¹(PDH) technique that was initially invented to stabilize the frequency of a laser to a high-finesse Fabry-Perot cavity, but works samewise the different way around to lock the cavity onto the laser. Remember, that a good feedback signal exhibits a huge change around the target frequency to which you want to stabilize.

PDH locking is used to realize mHz linewidth lasers for interrogating ultranarrow atomic transition (e.g., for implementing optical atomic clocks), and it is one key enabling technique for the recent detection of gravitational waves by LIGO, as it allows one to measure small changes in the length of the cavity with extremely good precision. The layout of the technique is shown below.

¹Named after Robert V. Pound (using such stabilization scheme in the famous Pound-Rebka experiment for detecting the gravitational red-shift of photons using nuclear resonance), Ronald W. P. Drever (co-founder of LIGO (Nobel Prize 2017)), John L. Hall (Nobel Prize 2005, together with Roy Glauber and Theodor W. Hänsch).

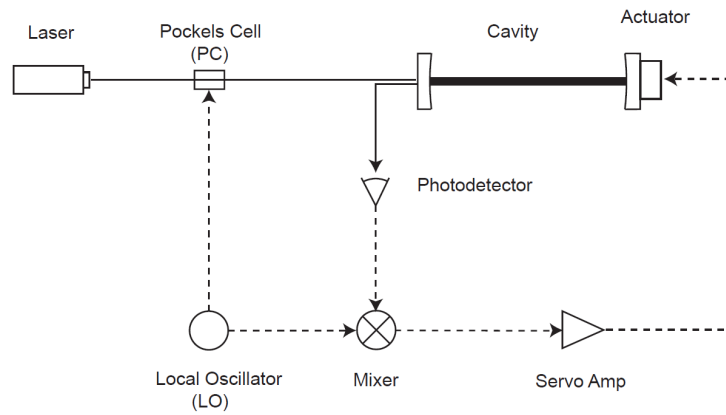

Figure 3: The layout of the Pound-Drever-Hall (PDH) method stabilize the cavity to a laser.

The light of a continuous-wave laser is frequency-modulated in a Pockels cell that is driven by the local oscillator and coupled into a Fabry-Perot cavity. The reflected light is captured with a photodetector. The oscillator signal and the signal from the photodetector is mixed and low-pass filtered. This signal is called the PDH error signal and is fed back to a piezo actuator in order to stabilize the length of the cavity. The following tasks should finally bring you to the derivation of this PDH error signal.

- (a) Start from the characteristics of the Fabry-Perot cavity and determine the reflection coefficient of the cavity. The incident field is

$$E_{\text{inc}} = E_0 e^{i\omega t} \quad (1)$$

and you can just think of how the reflected field E_{ref} evolves with every pass of the cavity. The amplitude will be affected by reflection coefficients r and transmission coefficients t that are connected via $t = \sqrt{1 - r^2}$ (no losses), whereas the phase is affected by a phase shift depending on the length of the cavity. The reflection coefficient then finally calculates to

$$F(\omega) = \frac{E_{\text{ref}}}{E_{\text{inc}}} = \frac{r \left(\exp \left(i \frac{\omega}{\Delta\nu_{\text{FSR}}} \right) - 1 \right)}{1 - r^2 \exp \left(i \frac{\omega}{\Delta\nu_{\text{FSR}}} \right)} \quad (2)$$

with ν_{FSR} the free spectral range or the distance between the resonance lines.

Plot the amplitude and phase of the reflection coefficient.

HINTS:

- i. Remember to account for the first reflection, that does not enter the cavity, and the corresponding phase shift.
- ii. You might want to use the relation

$$\sum_{n=0}^{\infty} x^{2n-1} e^{in/A} = \frac{x}{e^{-i/A} - r^2}$$

- (b) Now we want to make use of the electro-optic modulator (EOM). The local oscillator modulates via EOM the phase of the incident field as

$$E_{\text{inc,mod}} = E_0 e^{i(\omega t + \beta \sin \Omega t)} \quad (3)$$

where Ω is the modulation frequency, and β is the strength of the modulation. Decompose this expression by using Bessel functions. You will get three components: One that is oscillating at the fundamental frequency ω , and two that are shifted by the modulation frequency, denoted as sidebands. Consider the first-order sidebands in the following only!

HINT:

$$\begin{aligned} \cos(\beta \sin(\phi)) &= J_0(\beta) + 2[J_2(\beta) \cos(2\phi) + J_4(\beta) \cos(4\phi) + \dots] \\ \sin(\beta \sin(\phi)) &= 2[J_1(\beta) \sin(\phi) + J_3(\beta) \sin(3\phi) + J_5(\beta) \sin(5\phi) + \dots] \end{aligned}$$

- (c) In order to describe the measured signal from the photodetector, calculate the electric field detected in reflection, $E_{\text{ref,mod}}$, when a modulated incident field $E_{\text{inc,mod}}$ is applied to the cavity. Since the photodetector measures power, provide an expression for $P_{\text{ref,mod}} = |E_{\text{ref,mod}}|^2$.
HINT: Use $F(\omega)$ from equation (2)

- (d) In order to isolate the Ω term in the signal of the photodiode ($P_{\text{ref,mod}}$), a frequency mixer in combination with a low-pass filter is employed. To understand this procedure, think about the frequencies you will obtain after multiplying two sinusoidal oscillations with only slightly different frequencies.

After isolating the Ω term, the final appearance of the PDH error signal is determined by the modulation frequency. Only consider the case of a high modulation frequency. Given that, how does the behaviour of the sidebands distinguish from the carrier wave regarding the Fabry-Perot cavity? This helps you to reduce the terms of $P_{\text{ref,mod}}$ to a single one and find the PDH-error signal. Plot it and explain why the PDH error signal is beneficial over the signal that you would get from the photodiode without a Pockels cell in the setup.

HINT:

$F(\omega \pm \Omega) \approx -1$ for the case of high modulation frequency